

**SCHEMATIC**

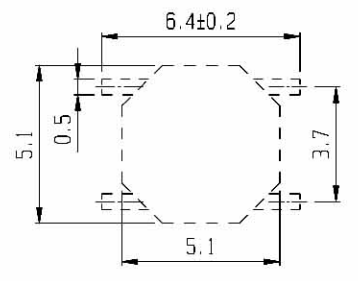

**PCB LAYOUT**

**RoHS Compliance**

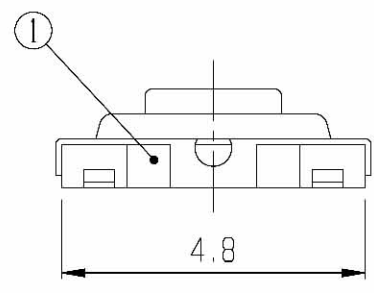
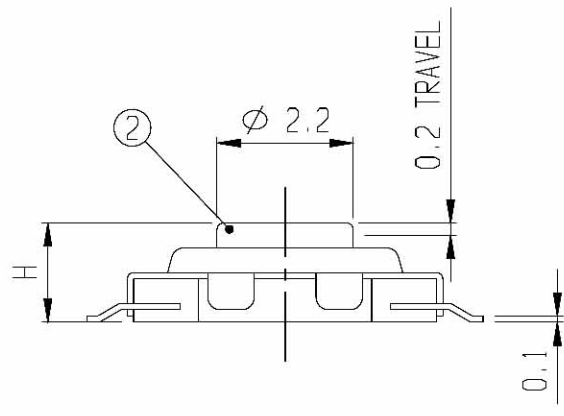

TC-12016-00-MK	1.7
TC-12016-00-CK	1.7
MODEL NO.	H

5	CONTACT	S U S	1	Ag PLATED	6	DUST COVER	POLYIMIDE	1	
3	TERMINAL	P B S	4	Ag PLATED	4	COVER	S U S	1	
1	FRAME	NYLON 46	1		2	NOB	BRASS	1	
NO	PART	MATERIAL	QTY	REMARKS	NO	PART	MATERIAL	QTY	REMARKS

<b>ISSUED</b>	<b>SPECIFICATION</b>	<b>TITLE: TACT SWITCH</b>							
	RATING: DC 12V 50mA	MODEL NO: TC-12016-00							
	CONTACT RESISTANCE: 100mΩ Max.								
	INSULATION RESISTANCE: 100MΩ at 500V DC	TOLERANCE	UNIT: MM	DWN.					
	WITHSTAND VOLTAGE: AC 250V for 1 minute.	UP TO 1.0:±0.1	SCALE: 8:1	CHK'D.					
	OPERATION FORCE: REFER ATTACH SPECIFICATION	1.0 TO 10.0:±0.2	VERSION: 02	APPD.					
	SWITCHING LIFE: 100k Cycles Min.	OVER 10.0:±0.3	DRWG NO:						

BY:   
 DATE: 07-NOV-2006

