

SCHEMATIC

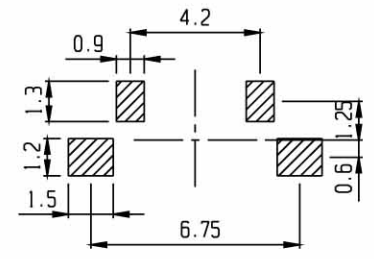

PCB LAYOUT

RoHS  
Compliance

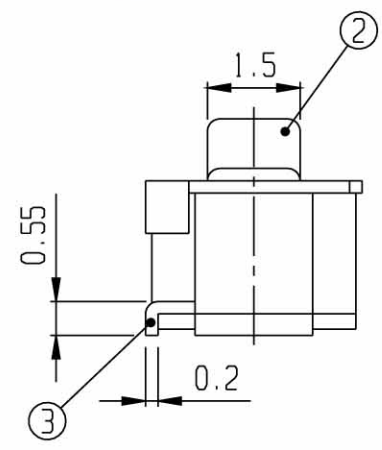
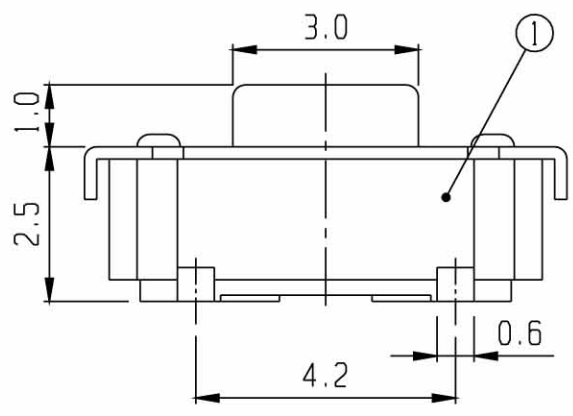

5	CONTACT	S U S	1						
3	TERMINAL	BRASS	2	Ag PLATED	4	COVER BOARD	BRASS	1 Ni PLATED	
1	FRAME	NYLON 46	1	HA	2	KNOB	NYLON 46	1 HB	
NO	PART	MATERIAL	QTY	REMARKS	NO	PART	MATERIAL	QTY	REMARKS

ISSUED	SPECIFICATION	TITLE: TACT SWITCH	
	RATING: DC 12V 50mA	MODEL NO: TC-06309-00	
	CONTACT RESISTANCE: 100mΩ Max.		
	INSULATION RESISTANCE: 100MΩ at 500V DC	TOLERANCE	UNIT: MM
	WITHSTAND VOLTAGE: AC 250V for 1 minute.	UP TO 1.0:±0.1	SCALE: 8:1
	OPERATION FORCE: REFER ATTACH SPECIFICATION	1.0 TO 10.0:±0.2	VERSION: 03
	SWITCHING LIFE: 30k Cycles Min.	OVER 10.0:±0.3	DRWG NO:
BY:			DWN.
DATE: 07-MAR-2007			CHK'D.
			APPD.

