

RoHS Compliance

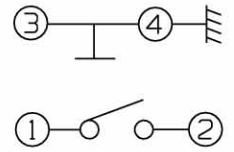

SCHEMATIC

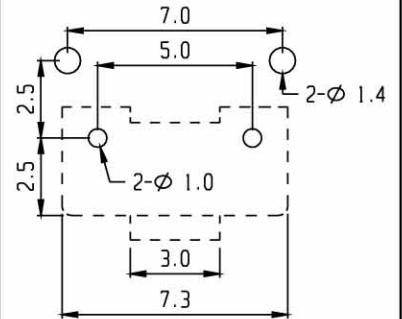

PCB LAYOUT

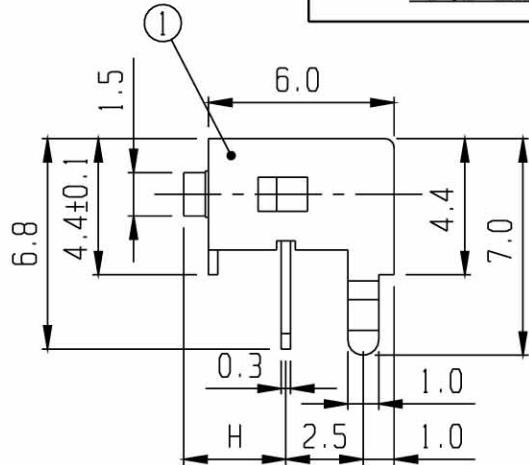
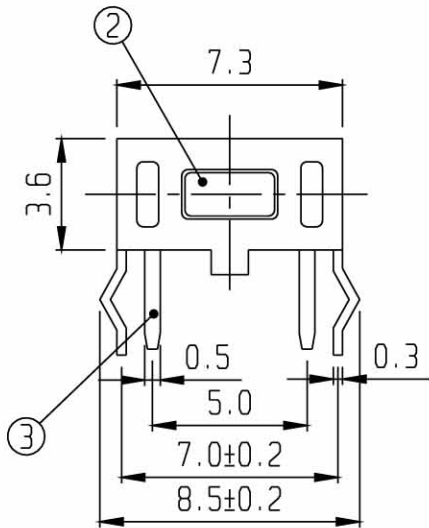

MODEL NO.	H
TC-00304-00	3.15
TC-00304(A)-00	3.85

5	CONTACT	S U S	1	Ag PLATED					
3	TERMINAL	BRASS	2	Ag PLATED	4	FRAME	NYLON	1	
1	SHELF	S U S	1		2	KNOB	NYLON	1	
NO	PART	MATERIAL	QTY	REMARKS	NO	PART	MATERIAL	QTY	REMARKS

ISSUED	SPECIFICATION	TITLE: TACT SWITCH	
	RATING: DC 12V 50mA	MODEL NO: TC-00304-00	
	CONTACT RESISTANCE: 100mΩ Max.		
	INSULATION RESISTANCE: 100MΩ at 500V DC	TOLERANCE	UNIT: MM
	WITHSTAND VOLTAGE: AC 250V for 1 minute.	UP TO 1.0:±0.1	SCALE: 4:1
	OPERATION FORCE: REFER ATTACH SPECIFICATION	1.0 TO 10.0:±0.2	VERSION: 02
	SWITCHING LIFE: 30k Cycles Min.	OVER 10.0:±0.3	DRWG NO:
			DWN.
			CHK'D.
			APPD.

BY: 
DATE: 07-MAR-2007

