

RoHS Compliance

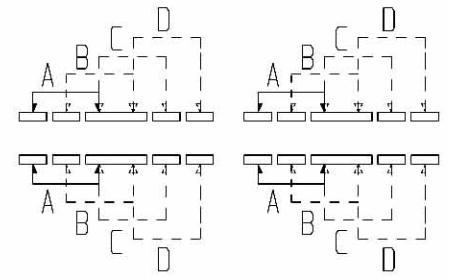

SCHEMATIC

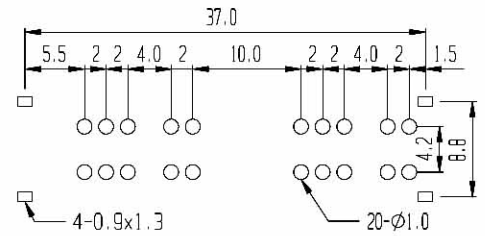

PCB LAYOUT

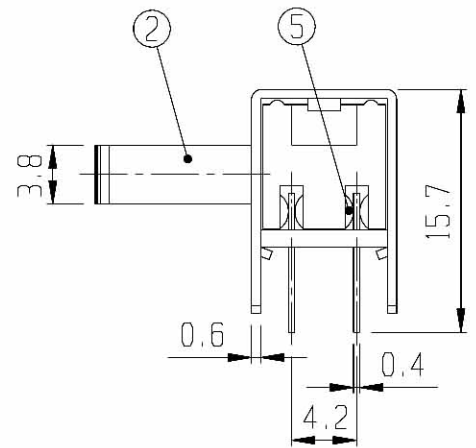
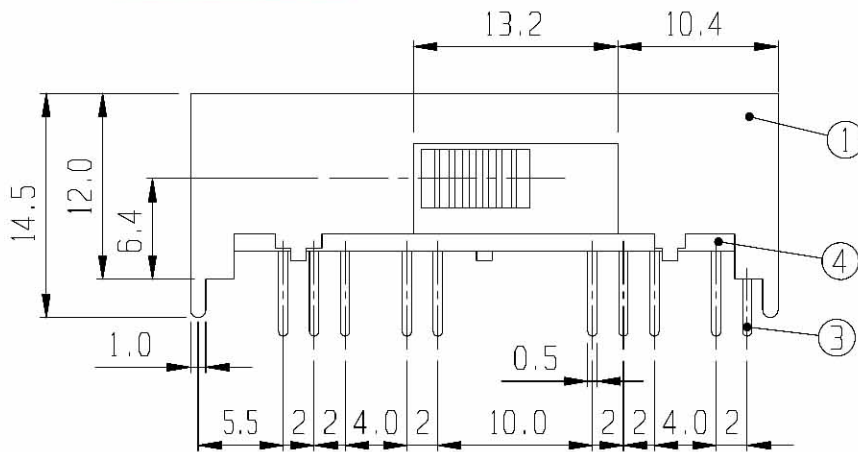

7	BALL	STEEL	1						
5	CONTACT	P B S	4	Ag PLATED	6	SPRING	STEEL WIRE	1	
3	TERMINAL	BRASS	20	Ag PLATED	4	TERMINAL BASE	PHENOL RESIN	1 NATURAL	
1	FRAME	S P C C	1	Ni PLATED	2	KNOB	P O M	1 G 2-16	
NO	PART	MATERIAL	QTY	REMARKS	NO	PART	MATERIAL	QTY	REMARKS

ISSUED

SPECIFICATION

TITLE: SIDE KNOB SLIDE SWITCH (4P4T)

RATING: DC 30V 0.5A
 CONTACT RESISTANCE: 30mΩ max.
 INSULATION RESISTANCE: 500MΩ at 500V DC
 WITHSTAND VOLTAGE: AC 500V for 1 minute
 OPERATION FORCE: REFER ATTACH SPECIFICATION
 SWITCHING LIFE: 10K cycles min.

MODEL NO: SK-44D01

TOLERANCE UNIT: MM
 UP TO 1.0: ±0.1 SCALE: 2:1
 1.0 TO 10.0: ±0.2 VERSION: 01
 OVER 10.0: ±0.3 DRWG NO:

DWN. *hno*
 CHK'D. *mn*
 APPD. *[Signature]*

BY: *[Signature]*
 DATE: 11-JUN-1999

