

ALLOWANCE	MARK	DATE	DESCRIPTION OF REVISION	APPROVED
UNDER 6 ±0.05	△	..		
6 TO 18 ±0.1	△	..		
18 TO 32 ±0.15	△	..		
32 TO 50 ±0.2	△	..		
50 OVER ±0.25	△	..		

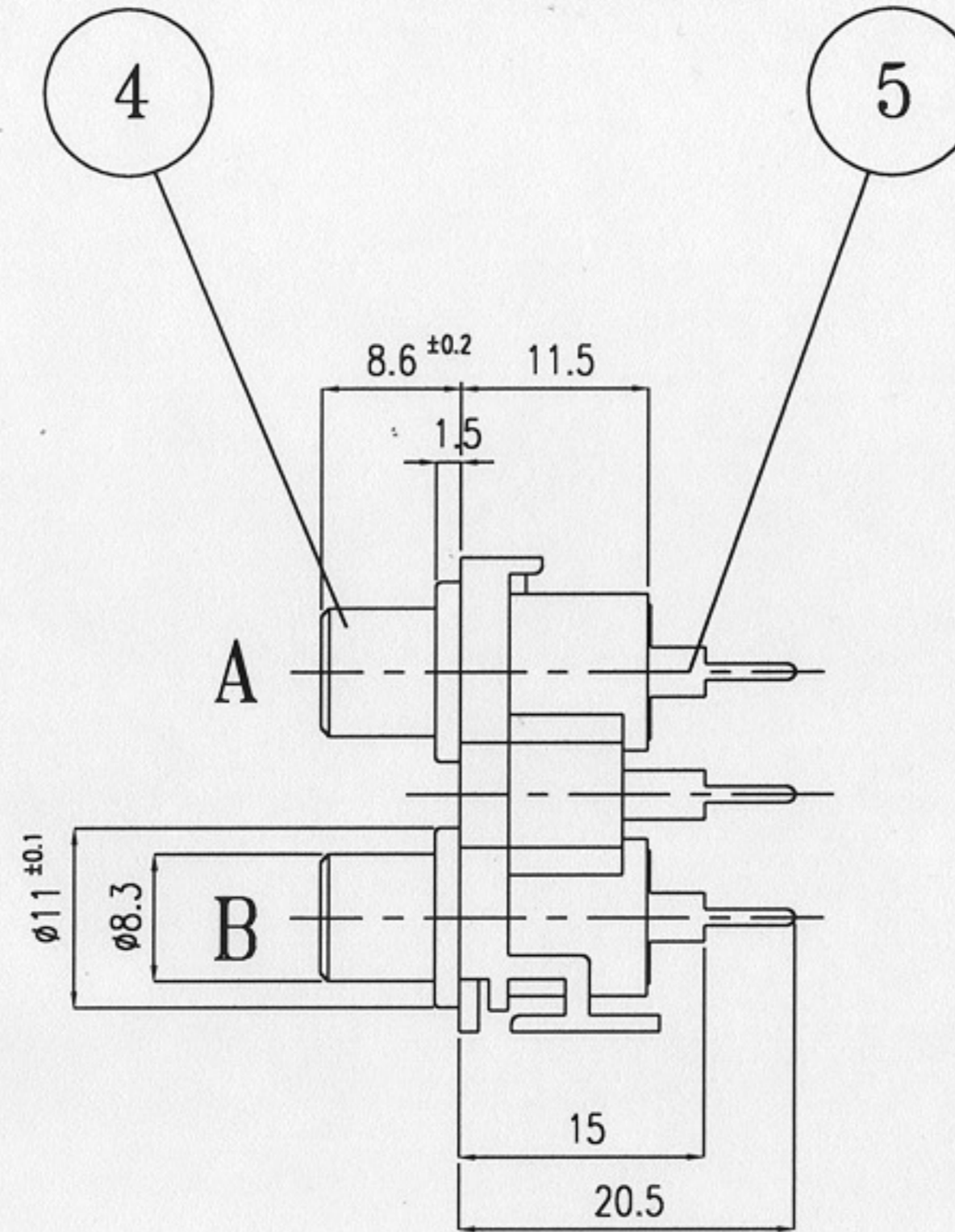

PCB-MTG

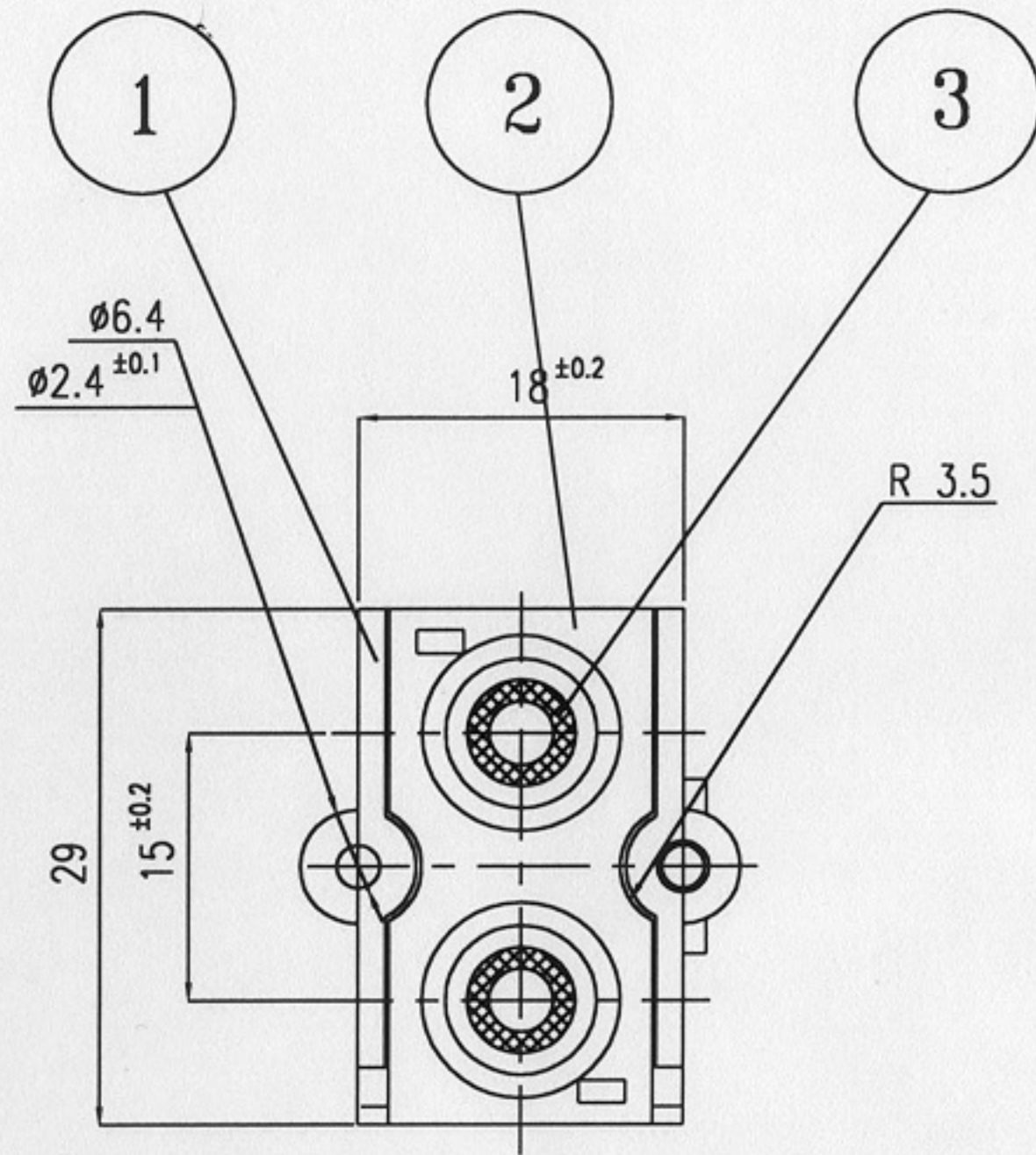
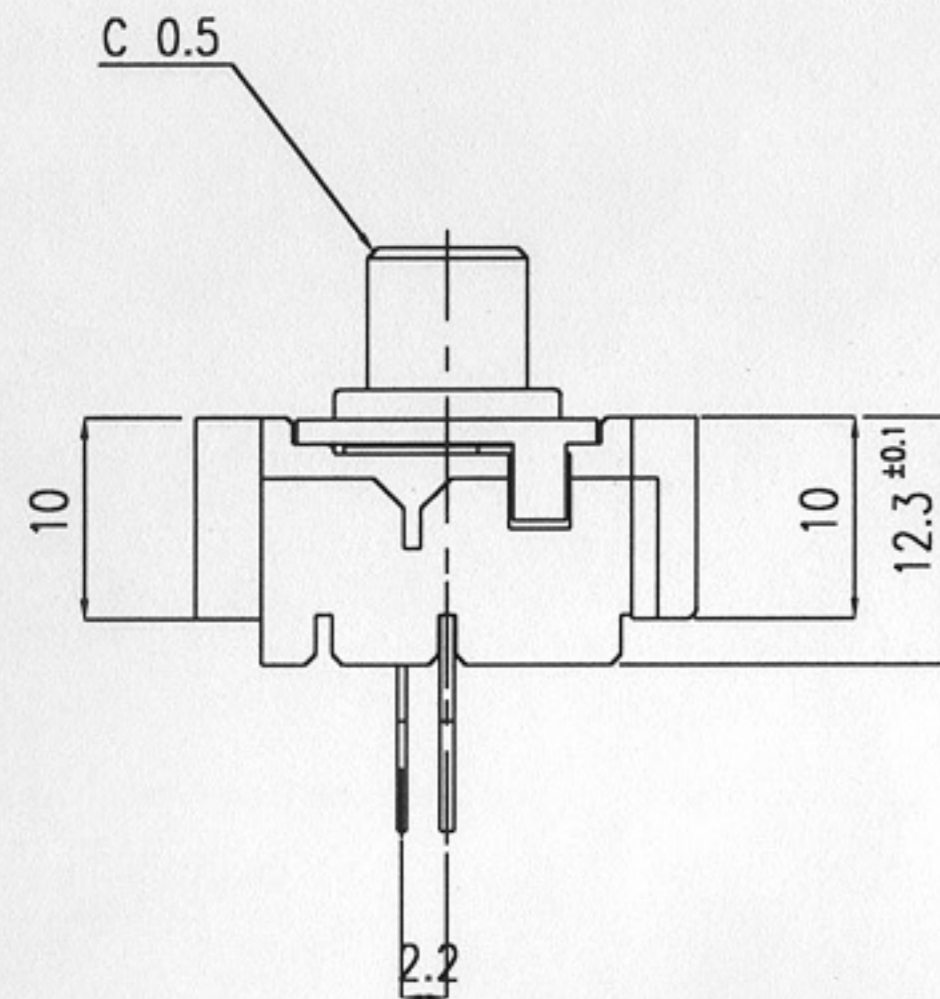
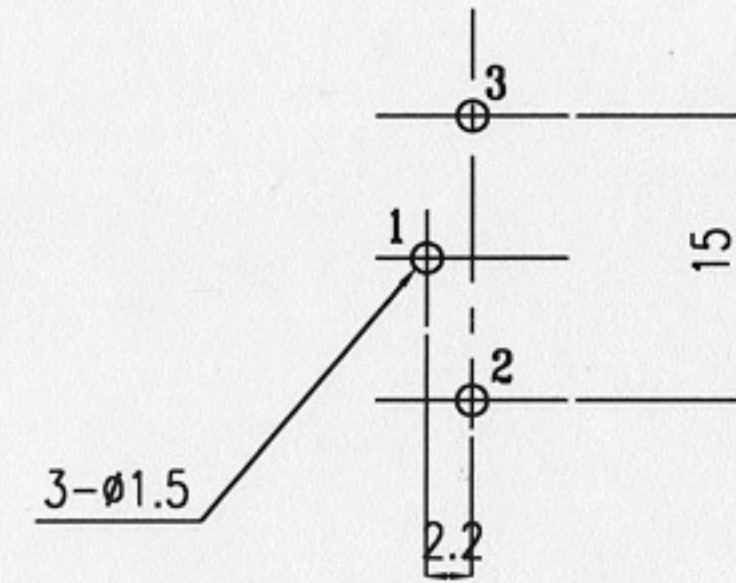

SCHEMATIC

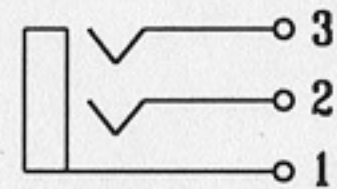

5	PIN	C2680 H 0.7t	2	P019	NI-PLATING
4	CAP GROUND	C2600 1-0 0.4t	1	P088	AU-PLATING
3	WASHER	ABS 94HB	2	M616	A; W B; R
2	COVER	ABS 94HB	1	M760	BLACK
1	BASE	ABS 94HB	1	M763	NP
NO	PART NAME	MATERIAL	QUANTITY	PART NO	REMARKS

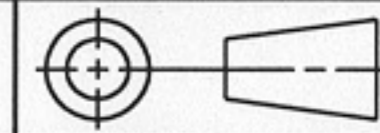

SCALE 2/1 DIMENSION ^m/_m

DRAWING	CHECKED	JUDGING	APPROVED	NAME TITLE	PIN JACK BOARD(2P)
1993.12.27	1993.12.27	1993.12.27		DRAWING NUMBER	J40200470G