

SCHEMATIC

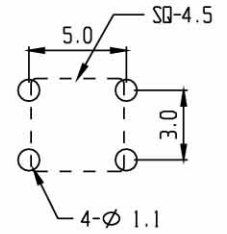

PCB LAYOUT

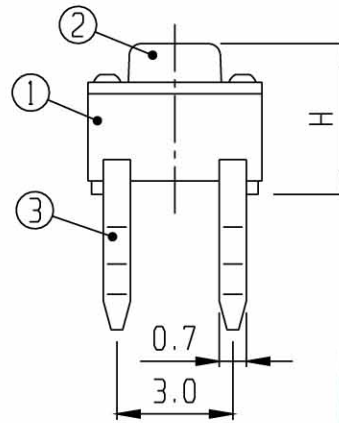
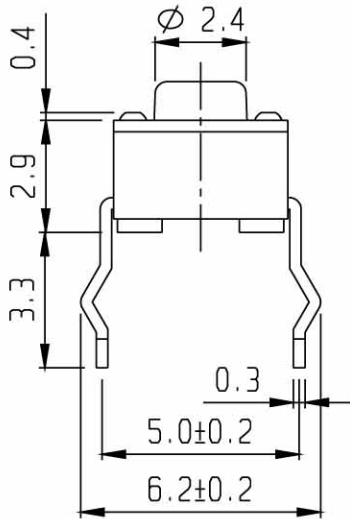

**RoHS
Compliance**

MODEL NO.	H
TC-00204-00	3.80
TC-00204A-00	7.00

5	CONTACT	S U S	1	Ag PLATED					
3	TERMINAL	BRASS	4	Ag PLATED	4	COVER BOARD	S P C C	1 S _n PLATED	
1	FRAME	NYLON 46	1		2	KNOB	NYLON 46	1	
NO	PART	MATERIAL	QTY	REMARKS	NO	PART	MATERIAL	QTY	REMARKS

ISSUED	SPECIFICATION	TITLE: TACT SWITCH	
	RATING: DC 12V 50mA	MODEL NO: TC-00204-00	
	CONTACT RESISTANCE: 100mΩ Max.		
	INSULATION RESISTANCE: 100MΩ at 500V DC	TOLERANCE	UNIT: MM
	WITHSTAND VOLTAGE: AC 250V for 1 minute.	UP TO 1.0:±0.1	SCALE: 5:1
	OPERATION FORCE: REFER ATTACH SPECIFICATION	1.0 TO 10.0:±0.2	VERSION: 01
	SWITCHING LIFE: 100k Cycles Min.	OVER 10.0:±0.3	DRWG NO:

BY: 
DATE: 11-SEP-2007

