

SCHEMATIC

RoHS Compliance

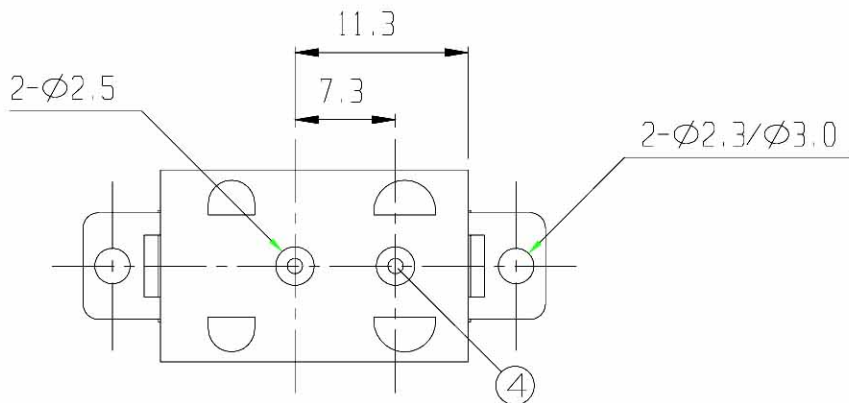
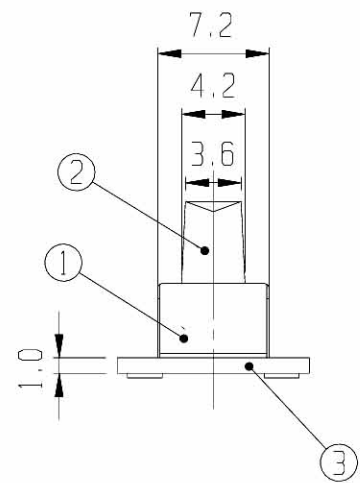
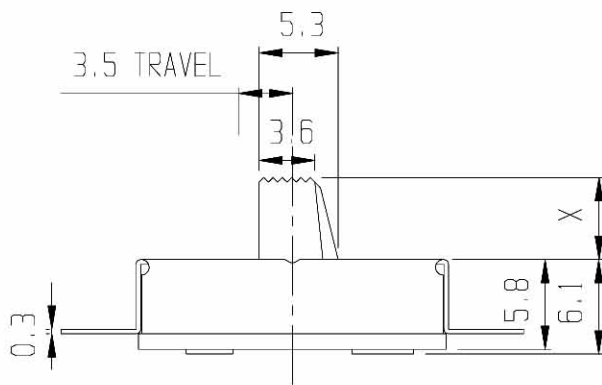

5	CONTACT	P B S	1	
3	TERMINAL BASE	PHENOL RESIN	1	NATURAL
1	FRAME	S P C C	1	NI PLATED
NO	PART	MATERIAL	QTY	REMARKS

4	NAIL	BRASS	2	
2	KNOB	A B S	1	AG 4.5,7,7.5
NO	PART	MATERIAL	QTY	REMARKS

ISSUED	SPECIFICATION			TITLE: SLIDE SWITCH (1P1T)	
	RATING: DC 30V 0.5A			MODEL NO: SS-11G01	
	CONTACT RESISTANCE: 30mΩ max.				
	INSULATION RESISTANCE: 100MΩ at 500V DC			TOLERANCE	UNIT: MM
	WITHSTAND VOLTAGE: AC 500V for 1 minute			UP TO 1.0:±0.1	SCALE: 2:1
	OPERATION FORCE: REFER ATTACH SPECIFICATION			1.0 TO 10.0:±0.2	VERSION: 01
	SWITCHING LIFE: 10K cycles min.			OVER 10.0:±0.3	DRWG NO:
BY:					DWN.
DATE: 18-JAN-2000					CHK'D.
					APPD.

