

MATING PLUG

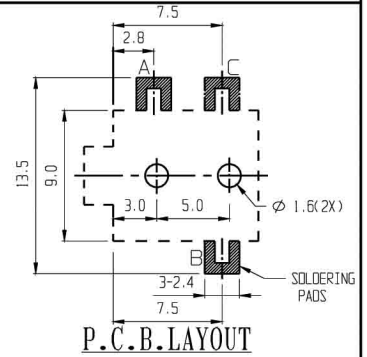

P.C.B. LAYOUT

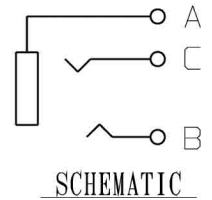
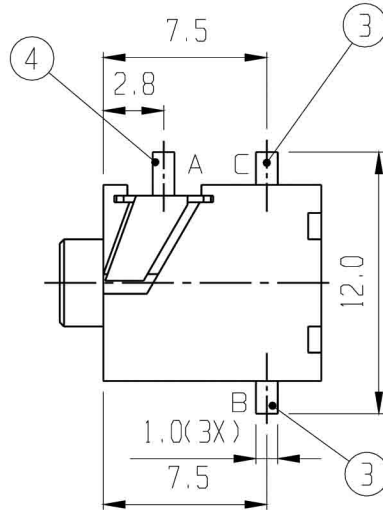

SCHEMATIC

RoHS Compliance

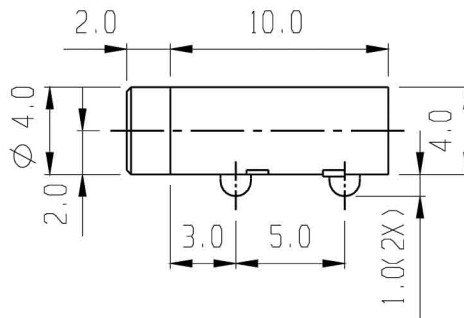
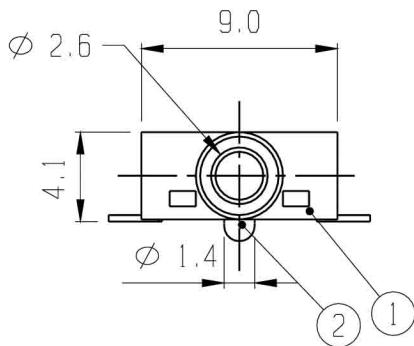

3	TERMINAL	P B S	2	Au PLATED	4	TERMINAL	P B S	1	Au PLATED
1	FRAME	NYLON 46	1		2	COVER BOARD	NYLON	1	
NO.	PART	MATERIAL	QTY	REMARKS	NO.	PART	MATERIAL	QTY	REMARKS

ISSUED

SPECIFICATION

TITLE: 2.5mm SMD STEREO JACK

RATING:	DC 30V 0.3A
CONTACT RESISTANCE:	50mΩ max.
INSULATION RESISTANCE:	100MΩ AT 500V DC
WITHSTAND VOLTAGE:	AC 500V for 1 minute
OPERATION FORCE:	REFER ATTACH SPECIFICATION
SWITCHING LIFE:	5,000 cycles min.

MODEL NO: SCJ-2593-SMT-A

TOLERANCE	UNIT: MM	DWN.	<i>hso</i>
UP TO 1.0:±0.1	SCALE: 3:1	CHK'D.	<i>pm</i>
1.0 TO 10.0:±0.2	VERSION: 01	APPD.	<i>[Signature]</i>
OVER 10.0:±0.3	DRWG NO:		

BY: *[Signature]*

DATE: 20-APR-2005

